



"Power Quality is our Only Business"

P.O. Box 330607
Ft. Worth, TX 76163
Phone: 817.483.8497
Fax: 817.572.2242
www.sinetamer.com

The SineTamer® RM series of units blends outstanding high-energy "impulse" suppression with excellent "ring-wave" transient protection utilizing our Frequency Attenuation Network®. This durable device is intended for general purpose and sensitive/critical load applications. The RM-ST120 is typically installed at small service entrances up to 800 amps, distribution and sub-distribution panels. Compact size and non-metallic enclosure design also allow it to be installed directly inside electrical panels and individual equipment disconnects. The internal installation provides the absolute shortest possible lead length and optimum performance. The RM-ST120 is extremely effective in limiting internally generated transients and is an absolute must on panels feeding office locations and/or microprocessor based equipment.

This economical device has features that are not available in devices costing many times its price. Its compact size makes installation a breeze. **Maintenance Free** operation and **15 Year Unlimited Free Replacement Warranty** provide peace of mind.

| GENERAL | |
|--------------------------------|---|
| Description: | Parallel connected, transient voltage surge suppressor device utilizing both high-energy handling and Frequency Attenuation Network® circuitry for virtual elimination of impulse and ring wave type transients. (tracking and monitoring the AC sine wave) |
| Application: | Designed for use at ANSI/IEEE Categories C, B and A with susceptibility up to medium exposure levels. Designed to protect sensitive/critical loads fed from distribution panels, branch panels and/or individual equipment panels. |
| Warranty: | 15 Years Unlimited Free Replacement |
| Product Qualifications: | Listed to UL1449 2 nd Edition (Feb. 9, 2007 Rev.) by CSA, an NRTL, CSA MC#214804, UL1283 and CE Compliant, ISO 9001:2000, ANSI C62.72-2007 |

| MECHANICAL | |
|---------------------------|--|
| Enclosure: | High strength ABS Plastic, NEMA 4 rated enclosure. |
| Mounting: | 3/4" conduit fitting (internally threaded) and external mounting feet. |
| Connection Method: | #10 stranded wire. |
| Shipping Weight: | ≈6lbs |

| ELECTRICAL | |
|-----------------------------------|---|
| Circuit Design: | Parallel connected, internally fused, hybrid design incorporating all mode protection, and utilizing our encapsulated design to provide improved durability. All suppression circuits are encapsulated in our exclusive compound to assure long component life and complete protection from the environment and/or vibration. |
| Protection Modes: | L-N, L-L (Normal Mode), and L-G, N-G (Common Mode). (Seven discrete modes) |
| Input Power Frequency: | 50-60Hz constant |
| Response Time: | <1 nanosecond |
| EMI/RFI Noise Attenuation: | 30dB Max. from 1kHz to 10MHz |
| Circuit Diagnostics: | Super Bright LED, 1 per phase, normally on. |
| Circuit Interrupt: | External and internal (see installation instructions for details). |
| Fusing: | Component Level Thermal and Board Level Current Fusing |
| kAIC Rating: | 200 kAIC when installed according to installation instructions |

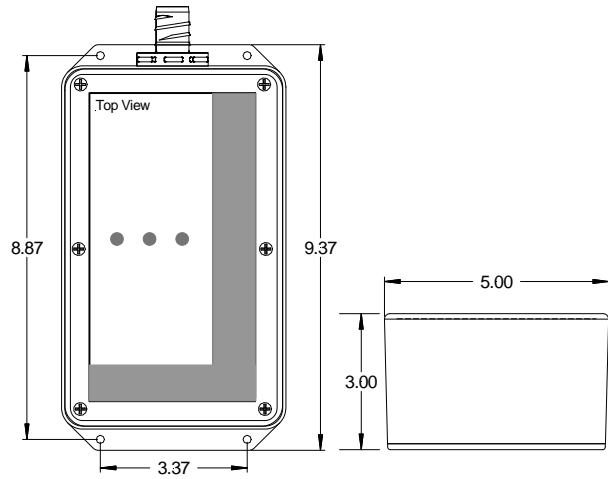

MEASURED LIMITING VOLTAGE PERFORMANCE AND ELECTRICAL SPECIFICATIONS

| Model | Circuit Type | MCOV | Peak Surge Current (Amps) Per Mode/Phase | Mode | ANSI/IEEE C62.41 & C62.45 Let-Through Voltage Test Results | | |
|---------------|---|--|--|--------------------------|---|--|---|
| | | | | | A1 2kV, 67A 100kHz Ring Wave 270° Phase Angle | B3/C1 6kV, 3kA Impulse Wave 90° Phase Angle | C3 20kV, 10kA Impulse Wave 90° Phase Angle |
| RM-ST120-1P1 | 120V, Single Ø (2 wire + ground) | 150 L-N 150 L-G 150 N-G | 40,000 / 80,000 | L-N L-G N-G | 70 85 60 | 385 400 565 | 925 1200 1200 |
| RM -ST120-1S1 | 120/240V, Split Ø (3 wire + ground) | 300 L-L 150 L-N 150 L-G 150 N-G | 40,000 / 80,000 | L-L L-N L-G N-G | 80 75 85 65 | 600 410 420 565 | 1200 914 1200 1200 |
| RM-ST120-3Y1 | 120/208V, 3ØY (4 wire + ground) | 300 L-L 150 L-N 150 L-G 150 N-G | 40,000 / 80,000 | L-L L-N L-G N-G | 80 75 85 65 | 600 410 420 565 | 1200 914 1200 1200 |
| RM -ST120-1P2 | 240V, Single Ø (2 wire + ground) | 320 L-N 320 L-G 320 N-G | 40,000 / 80,000 | L-N L-G N-G | 96 100 100 | 560 590 590 | 1050 1290 1290 |
| RM -ST120-3Y2 | 220/380V, 3ØY 277/480V, 3ØY (4 wire + ground) | 550 L-L 320 L-N 320 L-G 320 N-G | 40,000 / 80,000 | L-L L-N L-G N-G | 135 96 100 100 | 895 575 575 985 | 1400 1050 1400 1575 |
| RM -ST120-3N2 | 240V, 3ØΔ (3 wire + ground) | 320 L-L 320 L-G | 40,000 / 80,000 | L-L L-G | 96 100 | 643 643 | 1275 1275 |
| RM -ST120-3N4 | 380V, 3ØΔ 480V, 3ØΔ (3 wire + ground) | 550 L-L 550 L-G | 40,000 / 80,000 | L-L L-G | 140 140 | 915 915 | 1375 1375 |

Let-Through Voltage Test Environment: Positive Polarity. Time base=1ms. All voltages are peak ($\pm 10\%$). Surge voltages are measured from the insertion point of surge on the sine wave to the peak of the surge. All tests are Dynamic (voltage applied) except N-G which is static (no voltage applied). All tests were performed with 6 inches of lead length outside the device enclosure which simulates actual "as installed" performance.

Single-pulse, surge current testing for all modes at rated currents, is in compliance with NEMA LS 1-1992. Single-pulse, surge current capacities of 200,000 amps or less are determined by single-unit testing of all components within each mode. Present industry test equipment limitations require testing of individual components or sub-assemblies within a mode for single-pulse, surge current capacities over 200,000 amps.

Because we are constantly seeking to improve our products, specifications are subject to change at any time.

© 2008 ECS International Inc. Specification Last Changed 03/08 RM-ST120.doc